



42 Partners Limited

Unit 88 IMEX Business Park
Upper Villiers Street
Wolverhampton
WV2 4XB
UK
+44 (0) 1902 313142
42@42partners.com
<http://www.42partners.com>
registered in England: 3021552

Photometric Test Report

Job Ref. 42 / 5482
Report Ref. 42 / 5482 / 54824a
Report Date 2002.12.30

Customer Encapsulite

Luminaire catalog No. MT50 IP68 28W CLEAR
Luminaire description linear cylindrical luminaire
with clear cover
data derived from range test series

Lamp description 28W T5 1150mm HE
Lamp lumen output 2600lm
No. of lamps in luminaire 1

width of luminaire 0.050m
length of luminaire 1.260m
height of luminaire 0.050m

The luminaire has been treated as though it has 2 planes of symmetry through the 0°/180° plane and the 90°/270° plane.

Index to report	
Front page	1
This page	2
Product identification	3
Utilisation Factors	4
Principal Axes Intensities	5
Polar curves	6
Aspect Factors & Zonal Flux Table	7
Luminous Intensities	8
Glare Tables	12
Comments & Quick Design Table	13
CIE Luminance Calculations	14
CIE Glare Limiting (Soellner) Diagrams	15

All measurements taken in accordance with BS5225.

The photometric centre of the luminaire was taken as the centre of the lamp.

The photometric nadir was taken to be perpendicular to the front face of the reflector.

Job Ref. 42 / 5482
Report Ref. 42 / 5482 / 54824a
Report Date 2002.12.30

Customer Encapsulite

Luminaire catalog No. MT50 IP68 28W CLEAR
Luminaire description linear cylindrical luminaire
with clear cover
data derived from range test series

Lamp description 28W T5 1150mm HE
Lamp lumen output 2600lm
No. of lamps in luminaire 1



Light Output Ratios	Up	0.13
	Down	0.93
	Total	1.06

Lighting design calculations should be performed using an initial (100 hour) lumen output of 2600 lm

Spacing to Height Ratios	SHR NOM	1.75
	SHR MAX	1.83
	SHR MAX TRANS	2.43

Utilisation Factors UF(F) Standard Presentation SHR NOM = 1.75

Room Reflectances			Room Index											
C	W	F	0.75	1.00	1.25	1.50	2.00	2.50	3.00	4.00	5.00			
.70	.50	.20	N/A	.61	.68	.73	.81	.86	.90	.96	.99			
	.30		N/A	.52	.59	.64	.73	.79	.83	.90	.94			
	.10		N/A	.45	.52	.58	.66	.73	.78	.85	.90			
.50	.50	.20	N/A	.57	.63	.68	.75	.80	.84	.89	.92			
	.30		N/A	.49	.56	.61	.69	.74	.78	.84	.88			
	.10		N/A	.43	.50	.55	.63	.69	.73	.80	.84			
.30	.50	.20	N/A	.53	.59	.64	.70	.75	.78	.83	.86			
	.30		N/A	.47	.53	.58	.65	.70	.73	.79	.82			
	.10		N/A	.41	.48	.53	.60	.65	.69	.75	.79			
.00	.00	.00	N/A	.37	.43	.47	.54	.59	.62	.68	.71			
BZ Class			N/A	6	6	6	6	6	6	6	6			
CIE Flux code			33 / 61 / 83 / 87 / 106											
CIE Room Index			0.60	0.80	1.00	1.25	1.50	2.00	2.50	3.00	4.00	5.00	10.0	20.0
CIE DRR			0.21	0.28	0.34	0.41	0.46	0.54	0.60	0.65	0.70	0.74	0.81	0.85
CIE class			7 / 7 / 7 / 8 / 8 / 8 / 8 / 8 / 8 / 8 / 8 / 9 / -											
Flux Fraction Ratio			0.14											
DIN Class			1.06 B											

Calculated in accordance with CIBSE Technical Memorandum No. 5 1980
 In accordance with TM5, this UF table is valid for values of SHR from 0.5 below SHR NOM to 0.5 above SHR NOM. SHR MAX is a separate limitation.
 Reflectances given in the UF table are the effective reflectances of the ceiling cavity, walls and floor cavity, and must be determined for the actual room in which the luminaire will be used.
 UF(F),UF(W), and UF(C) for 0% reflectance of the room surfaces are equivalent to DF(F),DF(W) and DF(C) respectively.



Average Luminous Intensities (cd/Klm)

Angle	Transverse plane	Axial plane	Average all planes
0°	212.75	212.75	212.75
5°	212.99	212.01	212.26
10°	213.14	209.13	210.13
15°	213.33	204.14	206.49
20°	213.28	197.59	201.74
25°	212.79	188.94	195.76
30°	211.82	178.03	188.13
35°	210.41	165.62	179.11
40°	209.00	151.68	169.33
45°	207.93	135.94	158.55
50°	207.78	120.15	147.31
55°	206.86	101.53	136.14
60°	204.43	83.29	124.63
65°	200.25	63.93	114.80
70°	194.36	43.80	104.36
75°	185.22	25.85	92.63
80°	172.53	11.24	78.48
85°	158.77	2.34	63.42
90°	151.28	0.00	53.53
95°	148.75	0.00	46.09
100°	132.70	0.00	17.15
105°	109.27	0.00	1.54
110°	24.41	0.00	0.56
115°	0.92	0.00	0.22
120°	0.53	0.00	0.17
125°	0.00	0.00	0.00
130°	0.00	0.00	0.00
135°	0.00	0.00	0.00
140°	0.00	0.00	0.00
145°	0.00	0.00	0.00
150°	0.00	0.00	0.00
155°	0.00	0.00	0.00
160°	0.00	0.00	0.00
165°	0.00	0.00	0.00
170°	0.00	0.00	0.00
175°	0.00	0.00	0.00
180°	0.00	0.00	0.00



Job Ref. 42 / 5482
Report Ref. 42 / 5482 / 54824a
Report Date 2002.12.30

Customer Encapsulite

Luminaire catalog No. MT50 IP68 28W CLEAR
Luminaire description linear cylindrical luminaire
with clear cover
data derived from range test series

Lamp description 28W T5 1150mm HE
Lamp lumen output 2600lm
No. of lamps in luminaire 1

Luminous Intensities (cd/Klm)

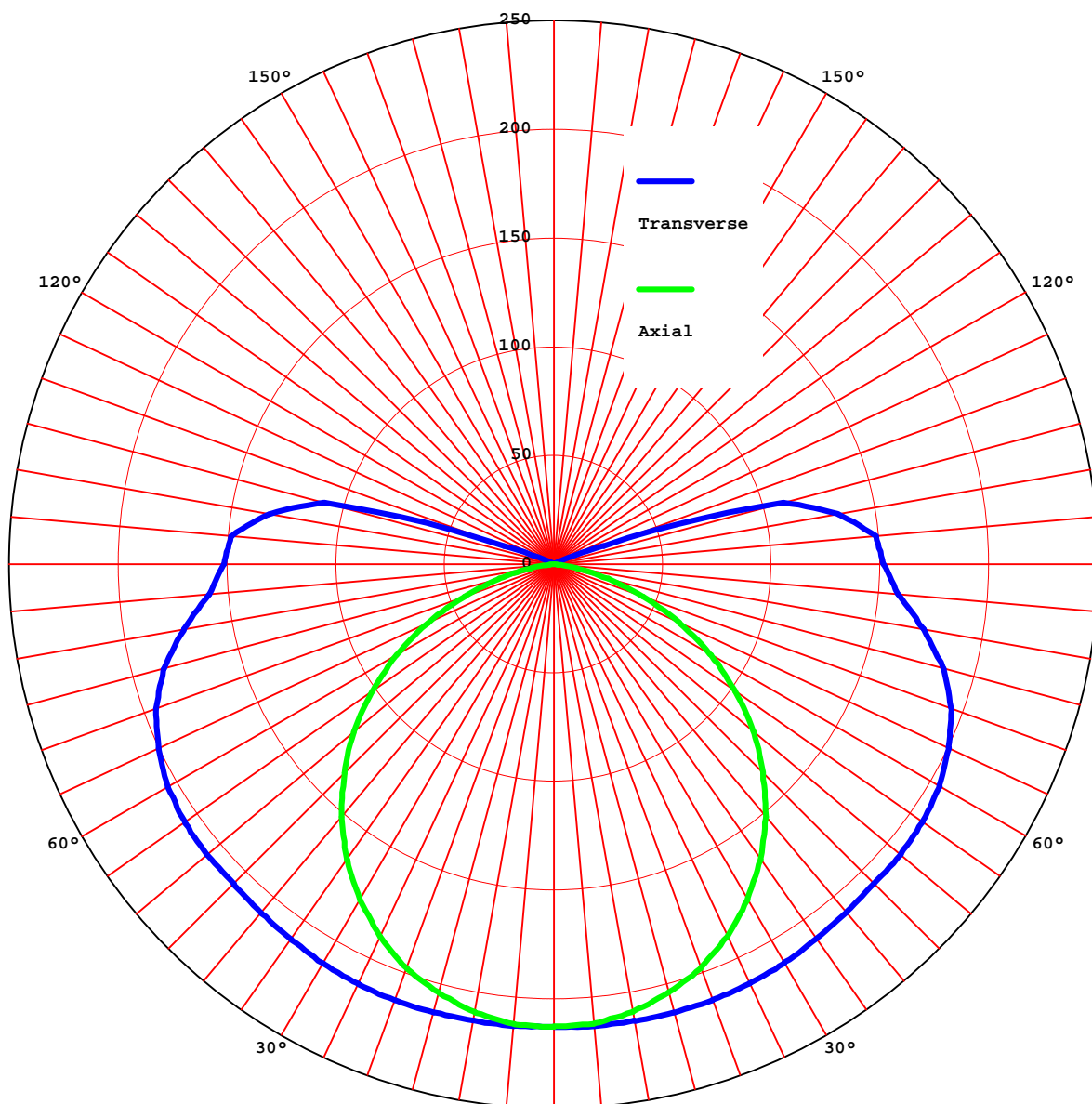

Angle

Aspect Factors

	Parallel plane	Perpendicular plane
0°	0.000	0.000
5°	0.087	0.004
10°	0.173	0.015
15°	0.255	0.033
20°	0.334	0.058
25°	0.407	0.089
30°	0.474	0.123
35°	0.533	0.161
40°	0.585	0.201
45°	0.628	0.241
50°	0.664	0.279
55°	0.692	0.315
60°	0.712	0.347
65°	0.726	0.374
70°	0.734	0.394
75°	0.739	0.408
80°	0.740	0.416
85°	0.741	0.418
90°	0.741	0.419

Zonal fluxes (Lumens)

Zone	% lamp	% luminaire
0°- 10°	2.0%	1.9%
10°- 20°	5.9%	5.6%
20°- 30°	9.3%	8.8%
30°- 40°	11.9%	11.2%
40°- 50°	13.5%	12.7%
50°- 60°	14.2%	13.4%
60°- 70°	14.0%	13.2%
70°- 80°	12.6%	11.9%
80°- 90°	10.0%	9.5%
90°-100°	8.8%	8.2%
100°-110°	4.7%	4.4%
110°-120°	0.0%	0.0%
120°-130°	0.0%	0.0%
130°-140°	0.0%	0.0%
140°-150°	0.0%	0.0%
150°-160°	0.0%	0.0%
160°-170°	0.0%	0.0%
170°-180°	0.0%	0.0%



Average Luminous Intensities (cd/Klm)

Angles	0°	30°	60°	90°	120°	150°
0°	212.7	212.7	212.7	212.7	212.7	212.7
5°	213.0	212.7	212.3	212.0	212.3	212.7
10°	213.1	212.3	210.1	209.1	210.1	212.3
15°	213.3	211.4	206.5	204.1	206.5	211.4
20°	213.3	209.7	201.7	197.6	201.7	209.7
25°	212.8	207.2	195.8	188.9	195.8	207.2
30°	211.8	204.6	188.1	178.0	188.1	204.6
35°	210.4	200.6	179.1	165.6	179.1	200.6
40°	209.0	196.8	169.3	151.7	169.3	196.8
45°	207.9	192.7	158.6	135.9	158.6	192.7
50°	207.8	189.2	147.3	120.1	147.3	189.2
55°	206.9	186.3	136.1	101.5	136.1	186.3
60°	204.4	182.7	124.6	83.3	124.6	182.7
65°	200.2	176.9	114.8	63.9	114.8	176.9
70°	194.4	169.5	104.4	43.8	104.4	169.5
75°	185.2	160.0	92.6	25.8	92.6	160.0
80°	172.5	147.8	78.5	11.2	78.5	147.8
85°	158.8	132.3	63.4	2.3	63.4	132.3
90°	151.3	124.5	53.5	0.0	53.5	124.5
95°	148.7	120.2	46.1	0.0	46.1	120.2
100°	132.7	104.0	17.1	0.0	17.1	104.0
105°	109.3	76.5	1.5	0.0	1.5	76.5
110°	24.4	1.1	0.6	0.0	0.6	1.1
115°	0.9	0.6	0.2	0.0	0.2	0.6
120°	0.5	0.5	0.2	0.0	0.2	0.5
125°	0.0	0.0	0.0	0.0	0.0	0.0
130°	0.0	0.0	0.0	0.0	0.0	0.0
135°	0.0	0.0	0.0	0.0	0.0	0.0
140°	0.0	0.0	0.0	0.0	0.0	0.0
145°	0.0	0.0	0.0	0.0	0.0	0.0
150°	0.0	0.0	0.0	0.0	0.0	0.0
155°	0.0	0.0	0.0	0.0	0.0	0.0
160°	0.0	0.0	0.0	0.0	0.0	0.0
165°	0.0	0.0	0.0	0.0	0.0	0.0
170°	0.0	0.0	0.0	0.0	0.0	0.0
175°	0.0	0.0	0.0	0.0	0.0	0.0
180°	0.0	0.0	0.0	0.0	0.0	0.0

Average Luminous Intensities (cd/Klm)

Angles	180°	210°	240°	270°	300°	330°
0°	212.7	212.7	212.7	212.7	212.7	212.7
5°	213.0	212.7	212.3	212.0	212.3	212.7
10°	213.1	212.3	210.1	209.1	210.1	212.3
15°	213.3	211.4	206.5	204.1	206.5	211.4
20°	213.3	209.7	201.7	197.6	201.7	209.7
25°	212.8	207.2	195.8	188.9	195.8	207.2
30°	211.8	204.6	188.1	178.0	188.1	204.6
35°	210.4	200.6	179.1	165.6	179.1	200.6
40°	209.0	196.8	169.3	151.7	169.3	196.8
45°	207.9	192.7	158.6	135.9	158.6	192.7
50°	207.8	189.2	147.3	120.1	147.3	189.2
55°	206.9	186.3	136.1	101.5	136.1	186.3
60°	204.4	182.7	124.6	83.3	124.6	182.7
65°	200.2	176.9	114.8	63.9	114.8	176.9
70°	194.4	169.5	104.4	43.8	104.4	169.5
75°	185.2	160.0	92.6	25.8	92.6	160.0
80°	172.5	147.8	78.5	11.2	78.5	147.8
85°	158.8	132.3	63.4	2.3	63.4	132.3
90°	151.3	124.5	53.5	0.0	53.5	124.5
95°	148.7	120.2	46.1	0.0	46.1	120.2
100°	132.7	104.0	17.1	0.0	17.1	104.0
105°	109.3	76.5	1.5	0.0	1.5	76.5
110°	24.4	1.1	0.6	0.0	0.6	1.1
115°	0.9	0.6	0.2	0.0	0.2	0.6
120°	0.5	0.5	0.2	0.0	0.2	0.5
125°	0.0	0.0	0.0	0.0	0.0	0.0
130°	0.0	0.0	0.0	0.0	0.0	0.0
135°	0.0	0.0	0.0	0.0	0.0	0.0
140°	0.0	0.0	0.0	0.0	0.0	0.0
145°	0.0	0.0	0.0	0.0	0.0	0.0
150°	0.0	0.0	0.0	0.0	0.0	0.0
155°	0.0	0.0	0.0	0.0	0.0	0.0
160°	0.0	0.0	0.0	0.0	0.0	0.0
165°	0.0	0.0	0.0	0.0	0.0	0.0
170°	0.0	0.0	0.0	0.0	0.0	0.0
175°	0.0	0.0	0.0	0.0	0.0	0.0
180°	0.0	0.0	0.0	0.0	0.0	0.0

Non Averaged Luminous Intensities (cd/Klm)

Angles	0°	30°	60°	90°	120°	150°
0°	212.7	212.7	212.7	212.7	212.7	212.7
5°	212.7	212.6	212.4	212.1	212.6	212.8
10°	212.6	212.3	210.3	209.3	210.8	212.9
15°	212.5	211.0	206.8	204.4	207.6	212.5
20°	212.3	209.4	202.0	198.2	202.8	211.0
25°	211.7	207.1	195.9	189.6	197.2	208.8
30°	210.6	204.2	188.4	179.0	189.8	206.0
35°	209.0	200.7	179.3	166.1	180.4	202.5
40°	207.6	196.8	170.5	152.9	170.8	198.4
45°	206.5	192.8	159.4	137.1	160.0	194.4
50°	206.3	189.2	148.8	121.9	148.8	191.0
55°	205.0	185.9	137.6	102.8	137.1	188.1
60°	202.9	182.5	126.0	84.2	126.0	184.4
65°	198.7	176.7	116.1	65.4	115.5	179.0
70°	193.3	169.7	105.8	44.7	104.7	171.3
75°	184.1	160.2	94.2	28.0	93.1	161.4
80°	171.5	149.1	79.0	11.6	79.1	148.7
85°	156.9	135.2	66.0	2.7	63.1	132.9
90°	149.2	124.1	54.8	0.0	52.7	125.6
95°	145.7	119.1	48.3	0.0	46.3	122.9
100°	130.3	104.4	26.9	0.0	15.0	105.8
105°	109.7	84.3	2.0	0.0	1.6	76.3
110°	24.5	1.0	0.7	0.0	0.4	1.0
115°	1.0	0.5	0.3	0.0	0.1	0.6
120°	0.4	0.4	0.2	0.0	0.1	0.5
125°	0.0	0.0	0.0	0.0	0.0	0.0
130°	0.0	0.0	0.0	0.0	0.0	0.0
135°	0.0	0.0	0.0	0.0	0.0	0.0
140°	0.0	0.0	0.0	0.0	0.0	0.0
145°	0.0	0.0	0.0	0.0	0.0	0.0
150°	0.0	0.0	0.0	0.0	0.0	0.0
155°	0.0	0.0	0.0	0.0	0.0	0.0
160°	0.0	0.0	0.0	0.0	0.0	0.0
165°	0.0	0.0	0.0	0.0	0.0	0.0
170°	0.0	0.0	0.0	0.0	0.0	0.0
175°	0.0	0.0	0.0	0.0	0.0	0.0
180°	0.0	0.0	0.0	0.0	0.0	0.0

Non Averaged Luminous Intensities (cd/Klm)

Angles	180°	210°	240°	270°	300°	330°
0°	212.7	212.7	212.7	212.7	212.7	212.7
5°	213.2	212.8	212.1	212.0	212.1	212.5
10°	213.6	212.6	209.8	208.9	209.6	211.5
15°	214.2	211.8	206.2	203.9	205.4	210.3
20°	214.3	210.2	201.3	197.0	200.8	208.1
25°	213.9	207.4	195.2	188.3	194.7	205.7
30°	213.0	204.7	187.8	177.1	186.6	203.5
35°	211.8	200.9	179.0	165.2	177.8	198.6
40°	210.4	197.4	168.8	150.4	167.2	194.6
45°	209.4	193.2	158.2	134.8	156.5	190.4
50°	209.3	189.4	147.2	118.4	144.5	187.3
55°	208.7	186.8	135.5	100.3	134.4	184.2
60°	206.0	182.9	124.3	82.4	122.2	180.9
65°	201.8	177.4	114.5	62.4	113.0	174.5
70°	195.5	169.7	104.5	42.9	102.5	167.4
75°	186.3	160.4	92.6	23.7	90.7	157.9
80°	173.5	148.1	79.2	10.9	76.7	145.3
85°	160.6	132.8	63.3	2.0	61.2	128.2
90°	153.3	126.3	54.9	0.0	51.7	122.0
95°	151.8	123.0	46.2	0.0	43.6	115.8
100°	135.1	105.1	11.3	0.0	15.5	100.8
105°	108.8	73.2	1.6	0.0	1.0	72.3
110°	24.4	1.1	0.7	0.0	0.5	1.2
115°	0.9	0.6	0.2	0.0	0.3	0.6
120°	0.7	0.5	0.2	0.0	0.2	0.6
125°	0.0	0.0	0.0	0.0	0.0	0.0
130°	0.0	0.0	0.0	0.0	0.0	0.0
135°	0.0	0.0	0.0	0.0	0.0	0.0
140°	0.0	0.0	0.0	0.0	0.0	0.0
145°	0.0	0.0	0.0	0.0	0.0	0.0
150°	0.0	0.0	0.0	0.0	0.0	0.0
155°	0.0	0.0	0.0	0.0	0.0	0.0
160°	0.0	0.0	0.0	0.0	0.0	0.0
165°	0.0	0.0	0.0	0.0	0.0	0.0
170°	0.0	0.0	0.0	0.0	0.0	0.0
175°	0.0	0.0	0.0	0.0	0.0	0.0
180°	0.0	0.0	0.0	0.0	0.0	0.0

Uncorrected Glare Indices

Reflectance of										
Ceiling	.70	.70	.50	.50	.30	.70	.70	.50	.50	.30
Wall	.50	.30	.50	.30	.30	.50	.30	.50	.30	.30
Floor Cavity	.20	.20	.20	.20	.20	.20	.20	.20	.20	.20

Room dimension		Viewed crosswise					Viewed endwise				
X	Y	0°					90°				
2H	2H	15.7	17.6	16.4	18.3	19.1	12.2	14.1	12.8	14.8	15.5
	3H	19.2	21.0	19.9	21.7	22.5	14.1	15.9	14.8	16.6	17.4
	4H	20.9	22.6	21.6	23.3	24.1	14.8	16.4	15.5	17.2	18.0
	6H	22.7	24.3	23.4	25.0	25.8	15.2	16.8	15.9	17.5	18.4
	8H	23.5	25.1	24.2	25.8	26.6	15.3	16.8	16.0	17.6	18.4
	12H	24.4	25.9	25.1	26.7	27.5	15.3	16.8	16.0	17.5	18.4
4H	2H	16.7	18.4	17.4	19.1	19.9	14.4	16.1	15.1	16.8	17.6
	3H	20.5	22.0	21.3	22.8	23.6	16.7	18.2	17.4	19.0	19.8
	4H	22.5	23.9	23.3	24.6	25.5	17.7	19.1	18.5	19.8	20.7
	6H	24.4	25.7	25.2	26.5	27.4	18.3	19.6	19.1	20.4	21.2
	8H	25.5	26.6	26.3	27.4	28.3	18.6	19.7	19.4	20.5	21.4
	12H	26.5	27.6	27.3	28.4	29.3	18.7	19.8	19.5	20.6	21.5
8H	4H	23.2	24.3	24.0	25.1	26.1	19.9	21.0	20.7	21.8	22.7
	6H	25.4	26.4	26.2	27.3	28.2	20.9	21.9	21.7	22.7	23.6
	8H	26.7	27.6	27.6	28.5	29.4	21.4	22.3	22.2	23.1	24.1
	12H	28.0	28.8	28.9	29.7	30.6	21.7	22.5	22.5	23.3	24.3
12H	4H	23.3	24.4	24.1	25.2	26.1	20.8	21.9	21.6	22.6	23.6
	6H	25.8	26.6	26.6	27.5	28.4	22.1	23.0	22.9	23.8	24.8
	8H	27.1	27.9	28.0	28.8	29.7	22.7	23.4	23.5	24.3	25.3

Calculated in accordance with CIBSE Technical Memorandum No. 10 1985

Luminance values

Using a lamp with an initial (100 hour) output of 2600 lm

Averaged Luminance values (cd/m²)

Angle	0°	30°	60°	90°	120°	150°	180°	210°	240°	270°	300°	330°
45°	8676	8416	7939	8508	7939	8416	8676	8416	7939	8508	7939	8416
50°	8964	8594	7814	8272	7814	8594	8964	8594	7814	8272	7814	8594
55°	9312	8879	7740	7834	7740	8879	9312	8879	7740	7834	7740	8879
60°	9697	9240	7698	7372	7698	9240	9697	9240	7698	7372	7698	9240
65°	10119	9604	7826	6695	7826	9604	10119	9604	7826	6695	7826	9604
70°	10595	10018	8005	5667	8005	10018	10595	10018	8005	5667	8005	10018
75°	11050	10457	8194	4420	8194	10457	11050	10457	8194	4420	8194	10457
80°	11464	10900	8272	2865	8272	10900	11464	10900	8272	2865	8272	10900
85°	12006	11289	8349	1190	8349	11289	12006	11289	8349	1190	8349	11289

Non Averaged Luminance values (cd/m²)

Angle	0°	30°	60°	90°	120°	150°	180°	210°	240°	270°	300°	330°
45°	8617	8419	7982	8581	8013	8490	8735	8440	7922	8436	7837	8314
50°	8901	8591	7892	8395	7891	8674	9028	8603	7806	8150	7666	8507
55°	9230	8865	7822	7930	7795	8967	9393	8906	7704	7737	7641	8780
60°	9624	9232	7781	7453	7783	9326	9769	9251	7680	7292	7546	9150
65°	10042	9594	7916	6853	7875	9717	10197	9630	7809	6537	7704	9475
70°	10535	10026	8115	5787	8033	10122	10655	10031	8013	5546	7861	9892
75°	10983	10472	8331	4788	8231	10548	11118	10483	8193	4051	8021	10323
80°	11397	10997	8325	2949	8333	10964	11531	10923	8349	2781	8084	10717
85°	11865	11537	8689	1382	8307	11346	12146	11334	8338	998	8060	10938

Glare Rating	Quality Class	Service values of illuminance (lx)							
		a	b	c	d	e	f	g	h
1.15	A	2000	1000	500	<300				
1.50	B		2000	1000	500	<300			
1.85	C			2000	1000	500	<300		
2.20	D				2000	1000	500	<300	
2.55	E					2000	1000	500	<300

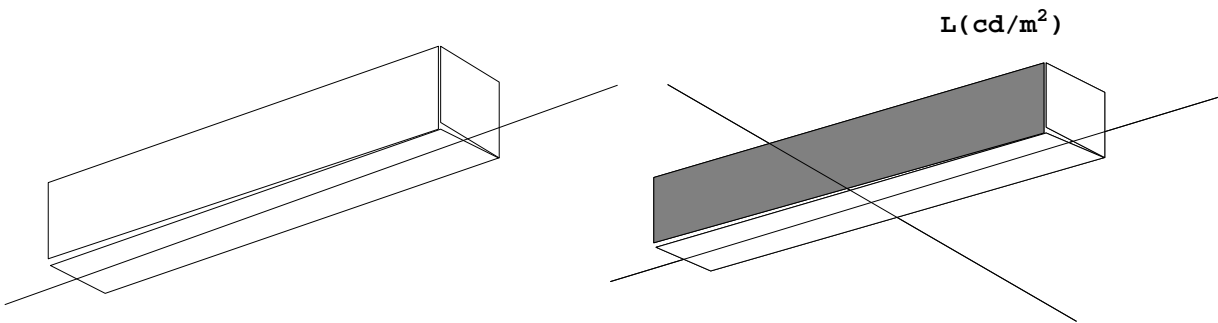
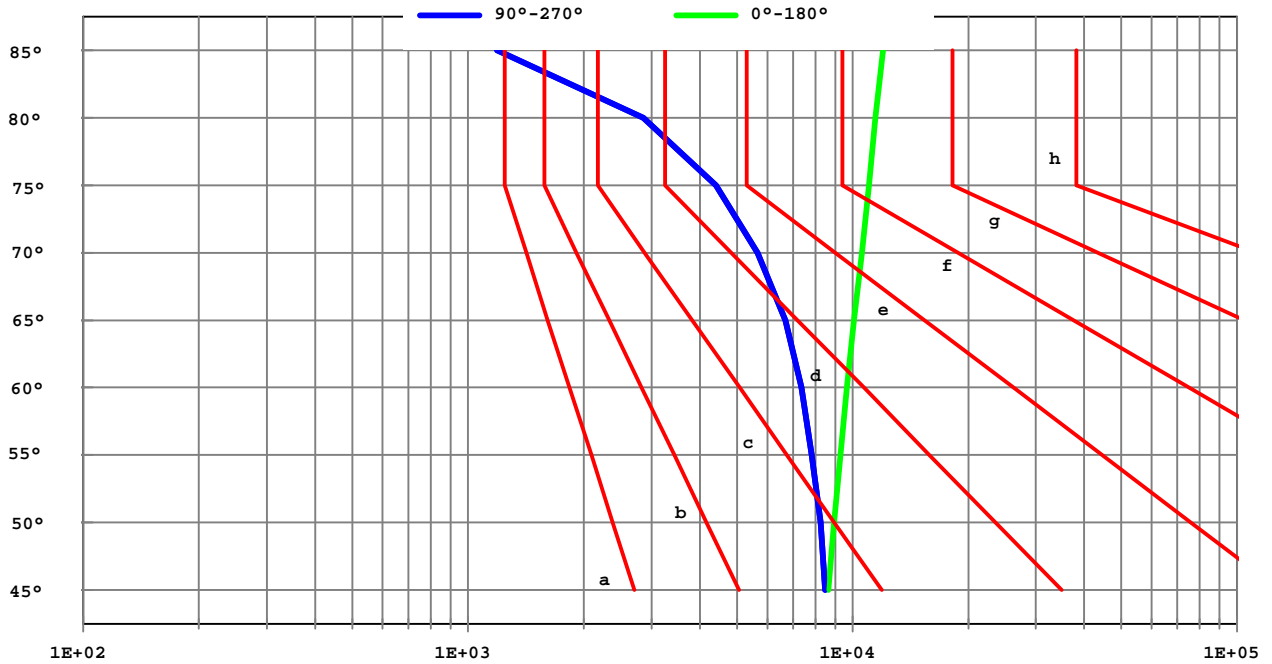

Glare Rating	Quality Class	Service values of illuminance (lx)							
		a	b	c	d	e	f	g	h
1.15	A	2000	1000	500	<300				
1.50	B		2000	1000	500	<300			
1.85	C			2000	1000	500	<300		
2.20	D				2000	1000	500	<300	
2.55	E					2000	1000	500	<300

